

Summary of Workshop in REHVA World Congress Clima 2007

WellBeing Indoors

WS 09

Enhanced Use of Weather Data and Forecasts to Improve the Energy Efficiency and Indoor Environment in Buildings

13th June 2007

Chair: Joachim Stelzer, Siemens Building Technologies, Switzerland
Joachim.stelzer@saarforst.saarland.de

Co-Chair: Jouko Pakanen, Helsinki University of Technology, Finland
jouko.pakanen@tkk.fi

Presentations:

1. Building simulation models integrated into building automation systems - Mika Vuolle, Helsinki University of Technology, Finland; Mikka.Vuolle@tkk.fi
2. Measurement and forecasting of microclimate of buildings and neighbourhoods - Matti Lyyra, Vaisala, Finland; matti.lyyra@vaisala.com
3. The use of weather forecasts in building automation and control systems (BACS): How to use them? What is the benefit? - Jürg Tödtli, Siemens Building Technologies, Switzerland; juerg.toedtli@siemens.com

Summary: Markus Gwerder, Siemens Building Technologies, Switzerland
markus.gwerder@siemens.com

INTRODUCTION

The indoor environment, energy use and life cycle costs of buildings are strongly influenced by the performance of building service systems. Recent developments in building automation, measurement techniques, data transfer and building simulation tools enable significant improvement potential of control of building systems. All the benefits of building automation systems are not in use currently. Enhanced use of local weather data and forecasts together with advanced building simulation tools could improve the performance, maintenance and the value of buildings remarkably.

DISCUSSIONS AND WS MAIN RESULTS

Within the workshop, several discussions were led, most of them based on the presentations. Here, these discussions are recapitulated by attaching them to three main questions. For each question, some answers that were either presented or discussed are given.

1. **How to use and make benefits of building simulation models integrated into building automation systems?**

- Compare actual building performance to set target values

- Evaluate performance of a building and its systems

Models can be used to compare different building performances: measured performance, simulated performance and target performance (see Figure 1). With calibrated models, system and component level performance estimations can be formulated (e.g. for the efficiency of heat recovery, for COP of cooling system with fans, free cooling etc.).

Comparisons can for example be used for fault diagnosis, too.

- Optimize the building and its system performance

Models can be used to optimize the building performance; both off-line and on-line applications are possible. A considerable performance increase can be expected by optimizing operating hours, night time ventilation, system set points, intermittent heating and cooling, embedded systems, integrated systems etc.

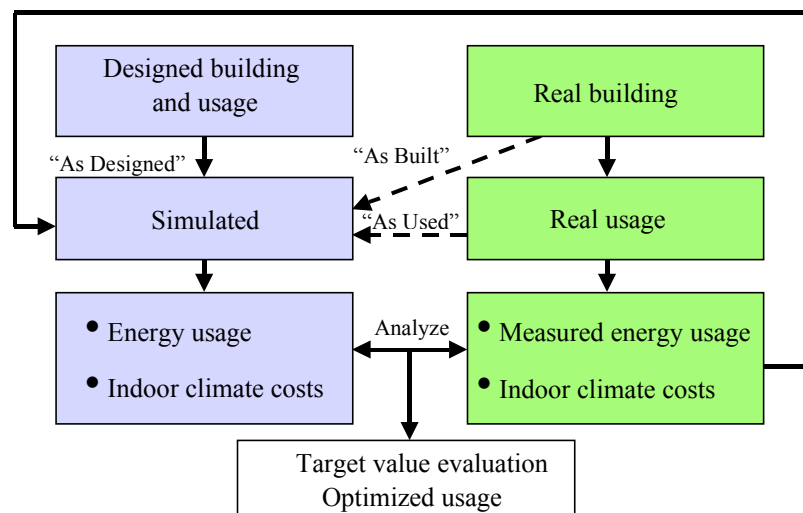

Figure 1: Use of simulation models (source: presentation M. Vuolle)

2. What can be gained by using weather forecasts in building automation?

- Better thermal indoor environment

- Lower energy consumption / energy costs

- Lower peak loads

- Improvement in usage of thermal inertia and storages

When the future weather is known, better thermal comfort can be achieved due to pre-heating or pre-cooling. Discomfort can be avoided due to the fact that actions can be initiated earlier. In addition, this can be done “soft” to further increase comfort.

If heating and cooling energy consumption and/or energy costs are related to weather data, the knowledge of the future weather can be used to make use of higher energy efficiencies, lower energy costs or lower peak loads. To be able to do this, a (thermal) storage – passive or active – has to be managed. In order to fully exploit the potential of the knowledge of the future weather, this storage has to have an appropriate capacity.

3. Which building automation applications are most promising to using weather forecasts for?

A promising predictive control application using weather forecasts should have at least one of the following properties:

- There is a thermal and/or electrical storage of an appropriate capacity that can be loaded and unloaded in a certain range
- There are setpoint ranges for controlled variables (e.g. comfort range for room temperature, temperature range of thermal storage), i.e. the controlled variables do not have to be controlled to specific values
- Future profiles of setpoint ranges are known
- Future profiles of disturbances (e.g. weather data profiles) are known or can be predicted well enough
- Future energy costs are known or can be predicted well enough
- Future limitations of energy sources are known or can be predicted well enough

Some applications which are promising:

- Peak load limiting

E.g. electrical peak load limiting: Electrical energy costs can be reduced drastically by avoiding peak loads.

- Combined heat and power (CHP) production (see Figure 2)

Heat and electrical power are produced simultaneously, normally not matching the actual heat and electrical power demand. Therefore, there usually is a storage (active or passive) that is managed which can be done using predictive control where future demand is taken into account, e.g. depending on weather forecasts.

- Solar collectors, PV

Future limitations of the usable solar energy are predicted (weather forecasts) and taken into account in the building automation decision making process.

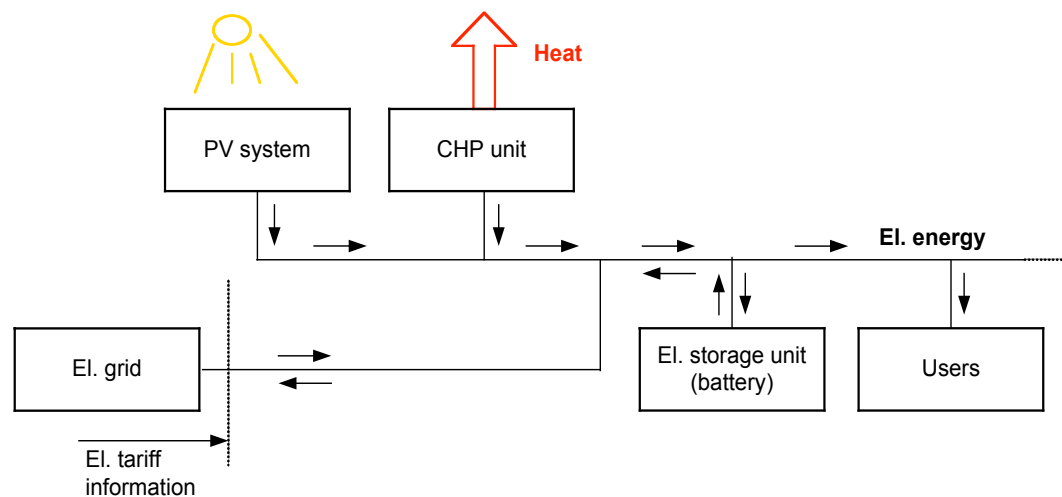

Figure 2: Example application: A building with PV panels, CHP-unit, etc. connected to the public electricity supply net and with variable or even dynamic electricity prices (source: presentation J. Tödli)

- Atriums

- Integrated room automation

(e.g. control of heating, cooling, blinds, artificial lighting)

Low operation cost energy sources (solar energy input controlled by blinds, “cold source” controlled by free cooling) can be used to reduce the need of high operation cost energy sources (heat controlled by heating system, cold controlled by chiller system).

The discussions in the workshop showed that the enhanced use of weather data and forecasts in buildings is supposed to have significant benefits. But how (which method) can the potential be exploited? What models are sufficient enough for the different tasks? Is it worth setting up complex models and calibrating them at all? Which control method should be used for a predictive control? Can better non-predictive control also lead to major improvements?

It was concluded that the answers to these questions can only be given dependent on the application. For some applications, there are already results from real-world implementations and/or simulations studies. For other applications, the investigation still has to be done.

CONCLUSIONS AND FUTURE WORK DIRECTIONS IN THE FIELD

In the workshop, it was generally agreed that the enhanced use of weather data and forecasts can lead to substantial benefits regarding energy efficiency and indoor environment in buildings. Moreover, this enhanced use can lower energy costs and peak demands. But not all building automation applications are promising. To identify the most promising applications and determine their potential, more research has to be done – particularly with regard to the use of weather forecasts.

During the last years substantial progress has been made in the areas of building technologies, weather forecasting, and model predictive control of dynamic systems. Major advances in information technology and sensorics, and a dramatic increase in the availability of low-cost computing power have also occurred. In Switzerland, the research project **OptiControl** which aims at exploiting these developments for improving the indoor climate control of buildings has been launched. The goal is to reduce energy consumption while maintaining high user comfort and work productivity, at modest basic investment and operating costs.

During the whole project, knowledge on the use of weather forecasts in building automation will be gathered and collected in a “knowledge base”.

Everybody is kindly invited to help in collecting this knowledge: Information (e.g. publications on the use of weather forecasts or of predictive control in BACS, information about real applications, information about standardization proposals for the communication of weather forecasts to building automation systems etc.) can be sent to the project leader of OptiControl, Dimitros Gyalistras at ETH, E-mail: gyalistras@env.ethz.ch.

References to such publications or real applications will be published on the website of the project OptiControl: <http://www.sysecol.ethz.ch/OptiControl>.

REFERENCES

1. **Predictive Control for Heating Applications**, P. Gruber, M. Gwerder, J. Tödtli, CLIMA 2000, Napoli, 2001.
2. **Predictive Control for Integrated Room Automation**, M. Gwerder, J. Tödtli, CLIMA 2005, Lausanne, 2005.
3. <http://www.sysecol.ethz.ch/OptiControl> (literature references).